

# Škoda Yeti; Modell 2009

EU-pedestrian protection guard 60low / EU-Personenschutzbügel 60niedrig  
EU-pedestrian protection guard 60 low with EU-horizontal pipe 42 /  
EU-Personenschutzbügel 60 niedrig mit Querrohr 42



## FITTING INSTRUCTIONS

Montageanleitung • Instructions de montage  
Instrucctionnes de montage • Manual

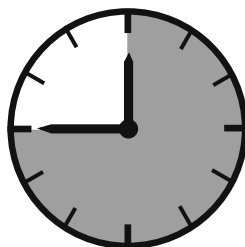

45 Minuten

### Artikel-Nr:

I4K 4013 Stainless Steel  
I4K 5013 Steel  
I4K 9013 Mounting Set

### Artikel-Nr:

I4K 4113 Stainless Steel  
I4K 5113 Steel  
I4K 9013 Mounting Set

Revision 2: 11.11.2009



# Škoda Yeti; Modell 2009

EU-pedestrian protection guard 60low / EU-Personenschutzbügel 60niedrig  
 EU-pedestrian protection guard 60 low with EU-horizontal pipe 42 /  
 EU-Personenschutzbügel 60 niedrig mit Querrohr 42

## Required tools / Benötigte Werkzeuge / Outillage requis / Herramientas necesarias

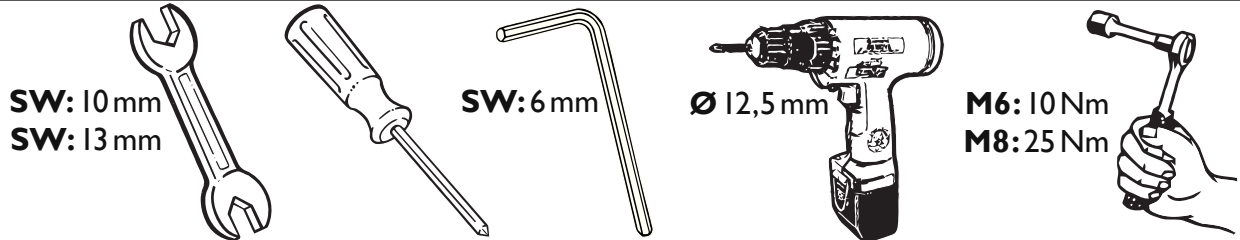

## Parts list / Teileliste / Lista de accesorios



## Mounting set 14K 9013 / Montagesatz 14K 9013

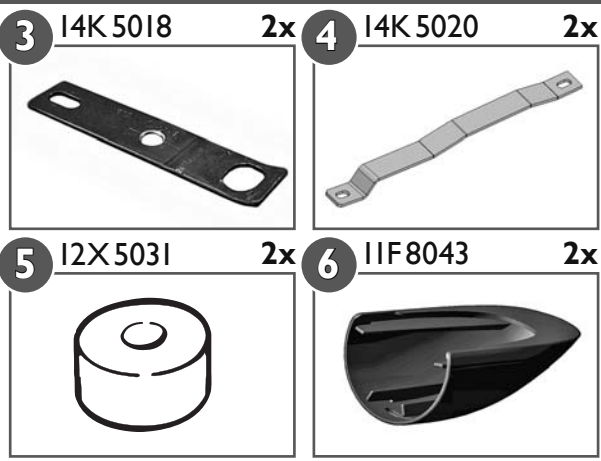

## Standard Parts list / Normteileliste

a		M6x25; DIN 933	4x
b		M8x20; DIN 933	2x
c		M8x30; DIN 933	1x
d		M8x50; DIN 933	1x
e		M8x20; DIN 912	2x
f		Ø6; DIN 127	4x
g		Ø8; DIN 127	6x
h		Ø6,4; DIN 9021	4x
i		Ø8,4; DIN 9021	4x
k		Ø8,4; DIN 125	2x
m		M6; Geto-Well	4x
n		SW 13mm	2x
o		Ø3,5x13; DIN 7981	2x

### Artikel-Nr:

14K 4013 Stainless Steel  
 14K 5013 Steel  
 14K 9013 Mounting Set

### Artikel-Nr:

14K 4113 Stainless Steel  
 14K 5113 Steel  
 14K 9013 Mounting Set

Revision 2: 11.11.2009

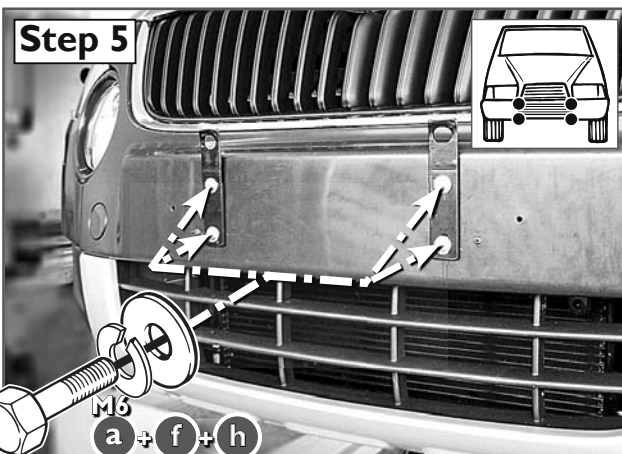
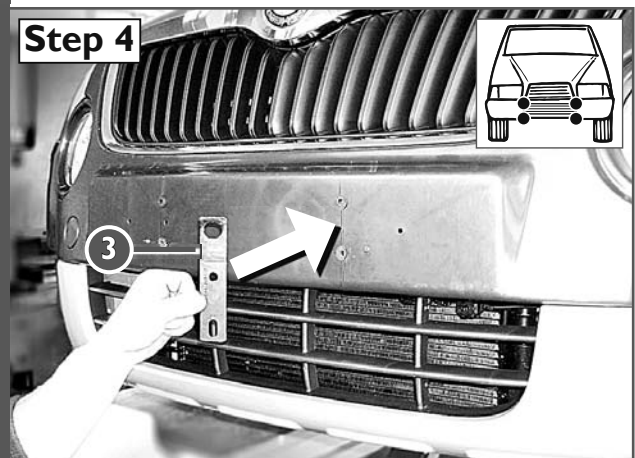
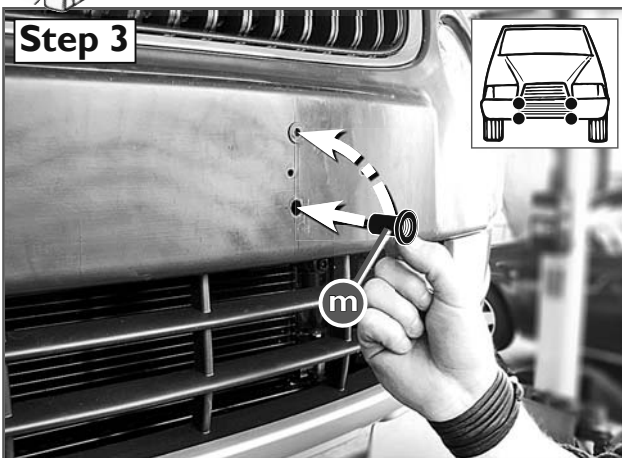
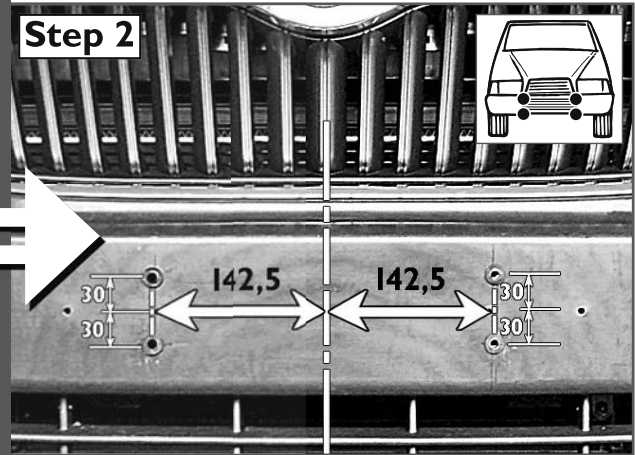

**Artikel-Nr:**  
14K 4013 Stainless Steel

**Revision 2:** 11.11.2009

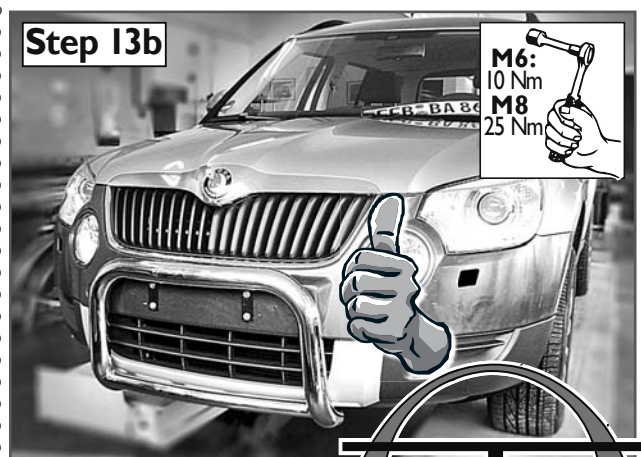
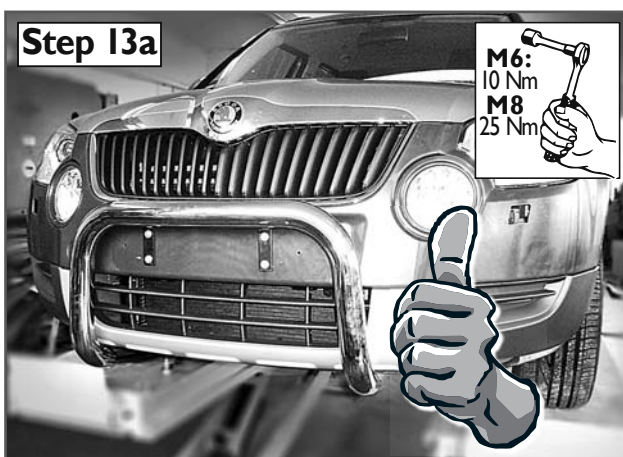
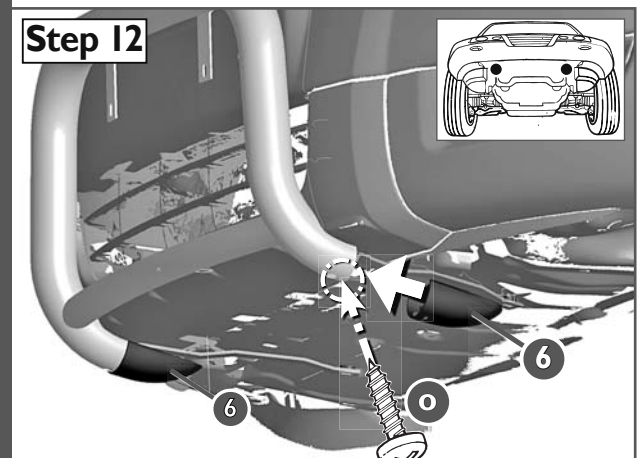
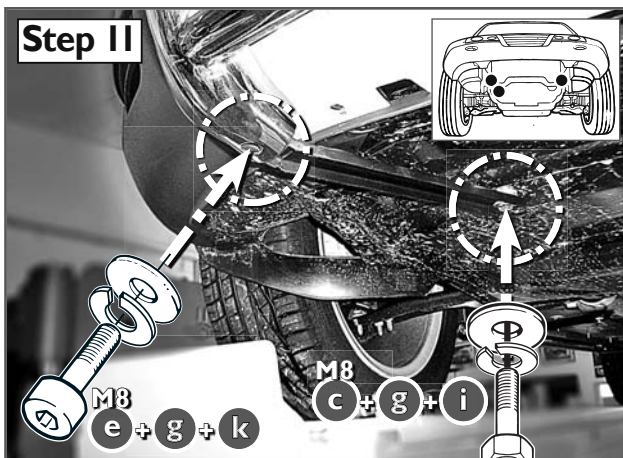
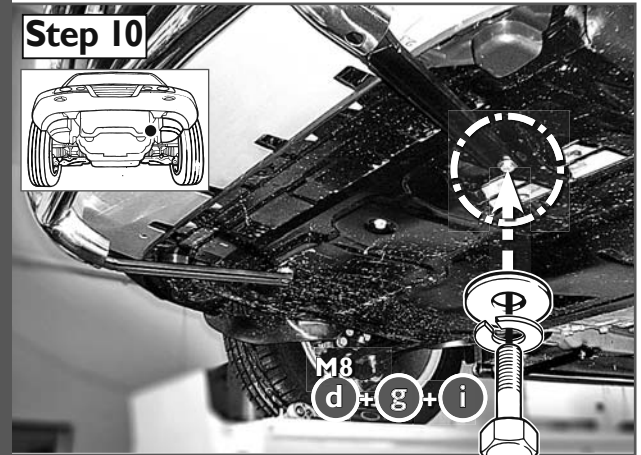
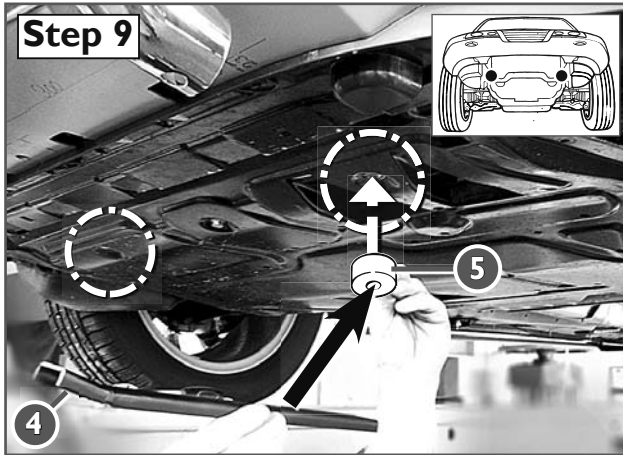
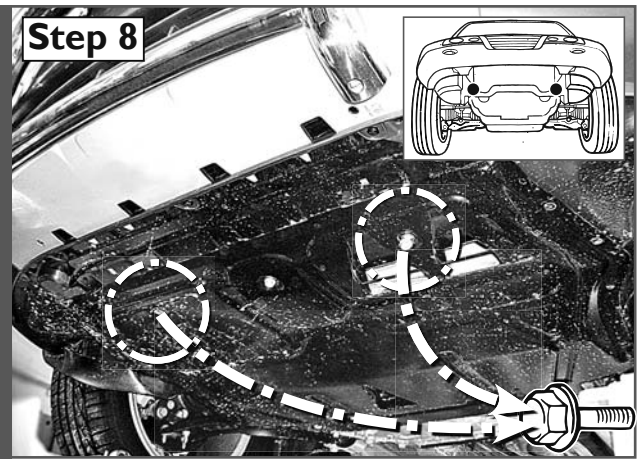
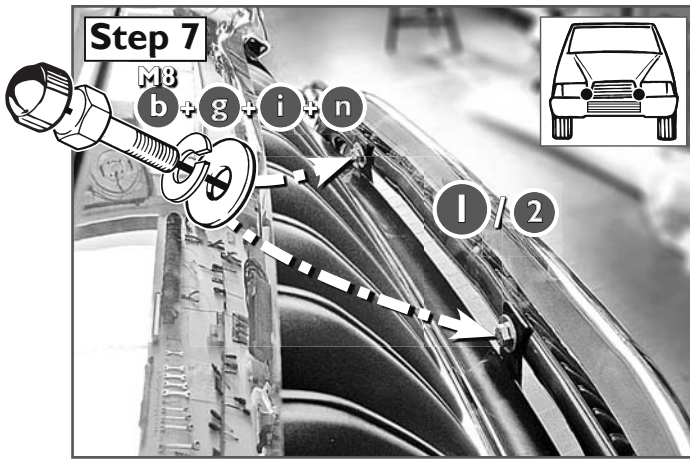

**Artikel-Nr:**  
14K 4013 Stainless Steel

**Revision 2:** 11.11.2009



[www.antec-online.de](http://www.antec-online.de)  
page/Seite 4