

Typ 824 05

Škoda Yeti 09/09 →

Milotec
AUTO-EXTRAS

Liftomat für Motorhaube • Plynová vzpěra kapoty motoru
Liftomat for engine hood • Liftomat pour capot moteur

Montageanleitung • Montážní návod • Fitting instructions • Instructions de montage



„Um eine Oxidation zu verhindern, empfehlen wir die verzinkten Gelenke unbedingt einzufetten“
„Kloubky vzpěry jsou zinkované, vhodná ochrana proti oxidaci je např. vazelína“
„In order to prevent oxidation, we point out that it is important to lubricate the galvanized joints“
„Veuillez absolument graisser les joints articulés galvanisés pour éviter toute oxydation“

Aus optischen Gründen und zum Schutz des Materials empfehlen wir die Halterungsschiene in Wagenfarbe zu lackieren.
Pro lepší vzhled doporučujeme nalakovat lištu vzpěry s adapterem do barvy vozu.
For optical reasons and to protect the material, we recommend painting the mounting rail in the colour of the car.
Pour des raisons estétiques, nous recommandons de vernir le rail de support dans la couleur du véhicule.

1.

Lieferumfang:
Obsah balení:
The pack contains:
Fournitures:

(A) 1 x

(B) 1 x

(C) 1 x

(D) 1 x M6

(E) 1 x 6,1

(F) 1 x M8

(G) 1 x 8,1

(H) 1 x

Montageanleitung
Montážní návod
Fitting instructions
Instructions de montage



Wichtiger Hinweis: der Liftomat steht unter Druck, deshalb darf der Druckbehälter nicht beschädigt werden.



Pozor! Plynová vzpěra je pod stálým tlakem. Tělo plynové vzpěry nesmí být poškozeno.



Important note: the pressure tank must not be damaged as the Liftomat is under pressure.



Note importante: Le Liftomat est sous pression, le réservoir à pression ne doit donc pas être détérioré.

2.

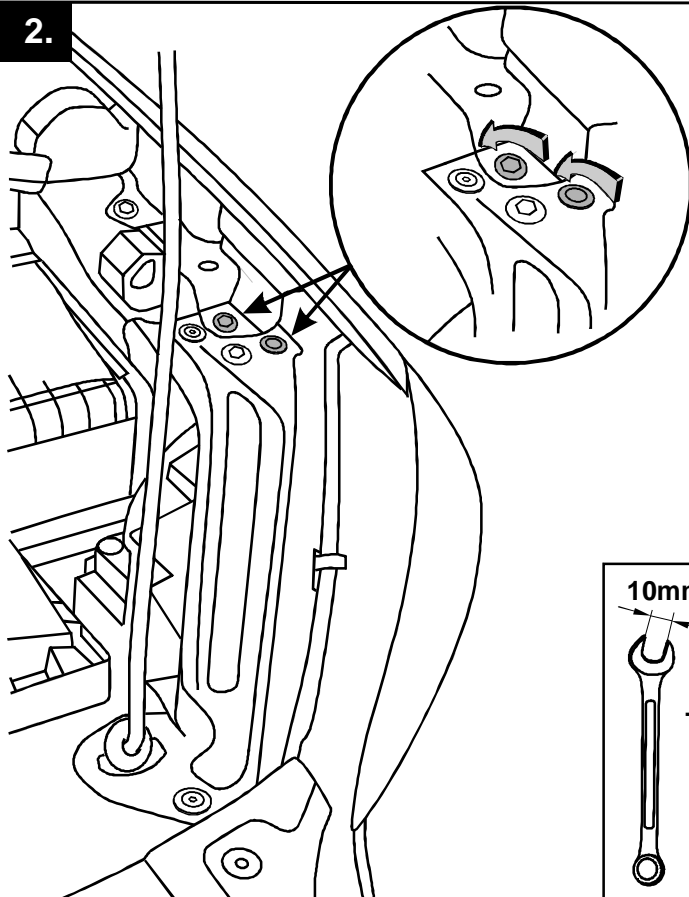

3.

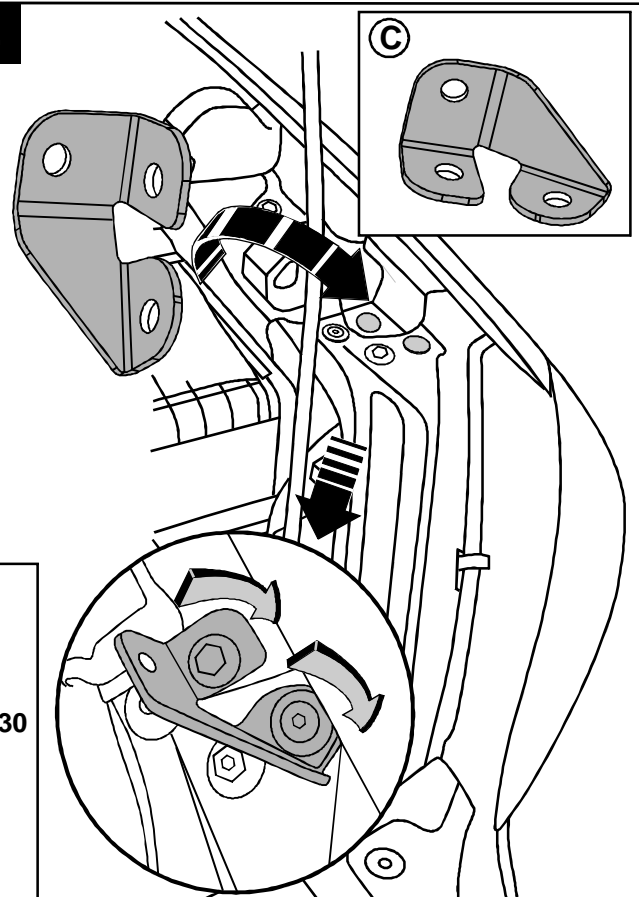

10mm

Torx 30

